

# MERKUR<sup>2</sup>

MANUÁL PRO REALIZACI  
TVAROVÝCH PRVKŮ TRAS

ARKYS<sup>®</sup>

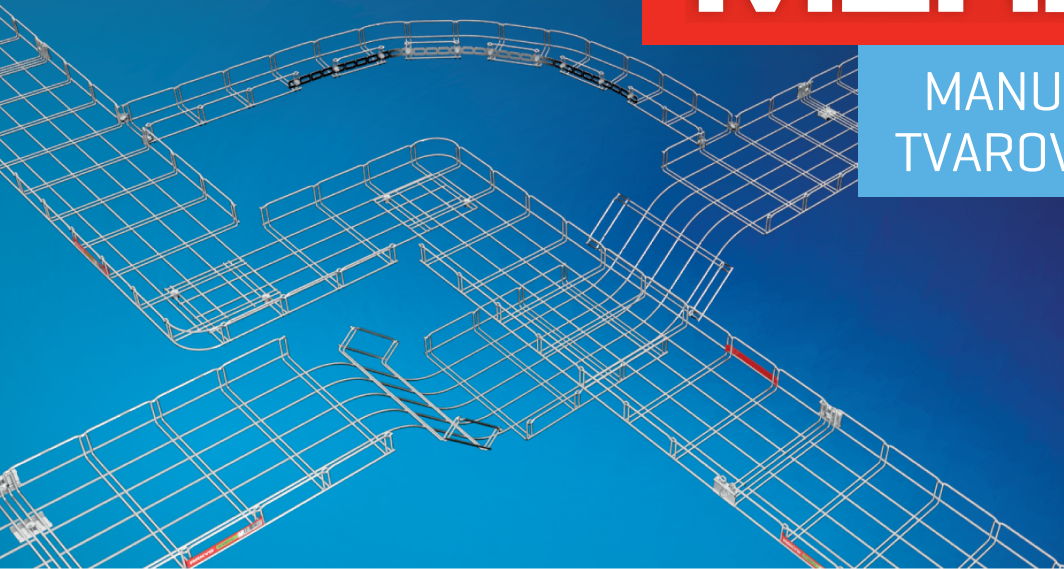



## **OBECNÉ POKYNY K TVAROVÁNÍ**

obecné informace a pokyny str. 5 – 7

## **ZÁKLADNÍ PRVKY TVAROVÁNÍ V ROVINĚ**

šířka žlabu 50 mm str. 8 – 10  
šířka žlabu 100 mm str. 11 – 13  
šířka žlabu 150 mm str. 14 – 16  
šířka žlabu 200 mm str. 17 – 19  
šířka žlabu 250 mm str. 20 – 22  
šířka žlabu 300 mm str. 23 – 25  
šířka žlabu 400 mm str. 26 – 28  
šířka žlabu 500 mm str. 29 – 31

## **KŘÍŽENÍ TRAS**

šířka žlabu 50, 100 mm str. 32  
šířky žlabu 150 - 500 mm str. 33

## **PROSTOROVÉ TVAROVÁNÍ**

výška bočnice 50, 100 mm str. 34  
prostorové míjení tras str. 35

## **NAPOJOVÁNÍ TRAS**

napojování tras různé šířky str. 36 – 37



klíč č. 10



ochranné pomůcky

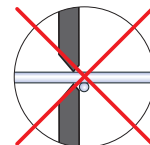
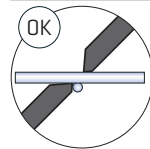
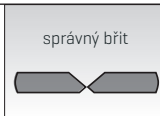
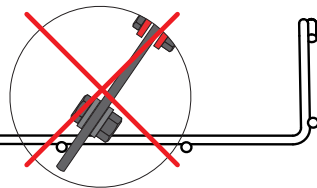
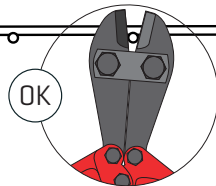
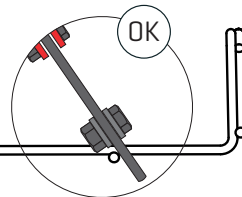
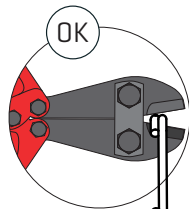

Pro dosažení deklarované nosnosti kabelové trasy je nutné vždy před a za tvarovanou částí použít vhodné kotvící prvky [viz příslušenství MERKUR]

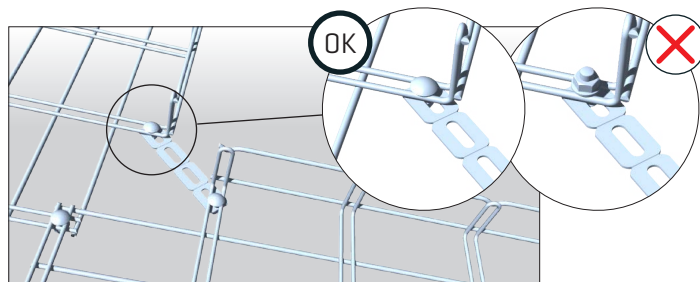
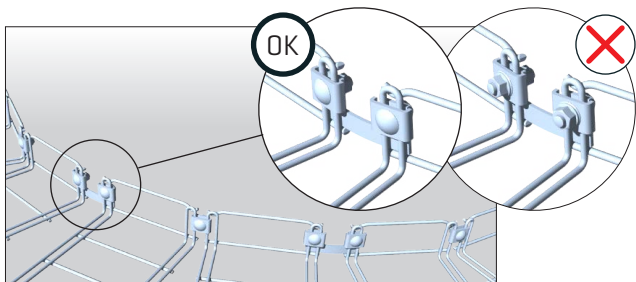

## POUŽITÉ PRVKY A PŘÍSLUŠENSTVÍ

### spojka tvarovací SZM 4

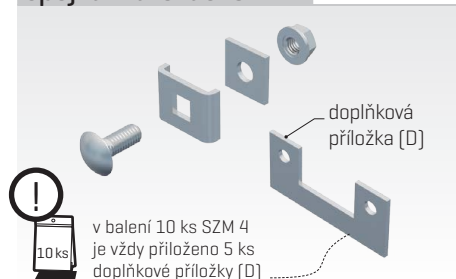

### tvarovací pásek TPM 1000

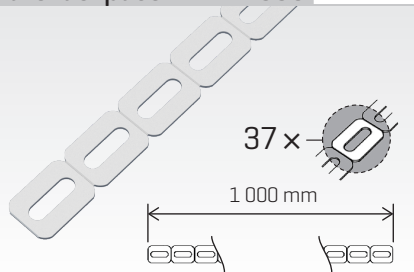

### spojovací sada SPM 1



## spojka žlabu SZM 1

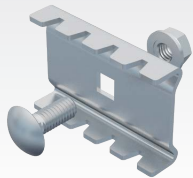

## spojka žlabu SZM 1-R

bezšroubová spojka pro rychlou montáž

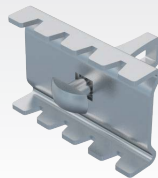

## ochranná krytka pro dráty OK 1

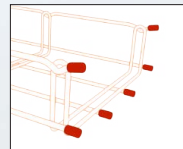

## nůžky MERKUR

boční břit

správný břit



nesprávný břit



## sprej zinkový zinek 98% [400 ml]



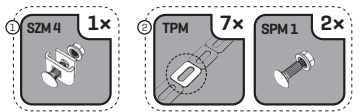
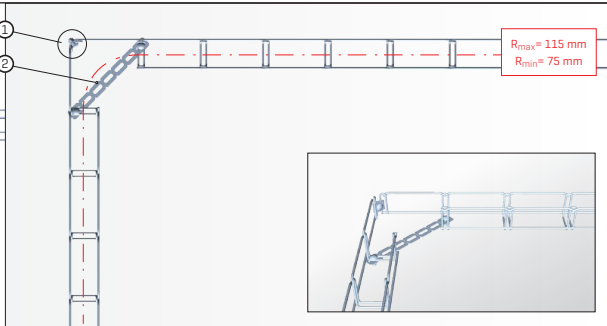
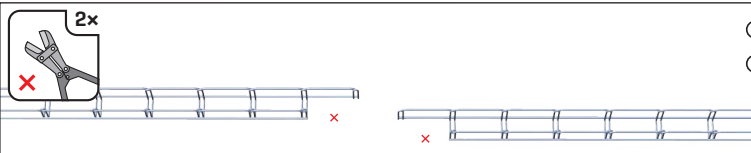
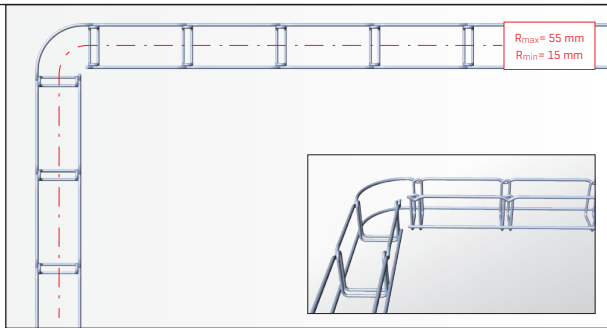
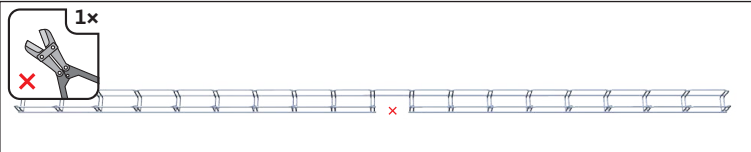



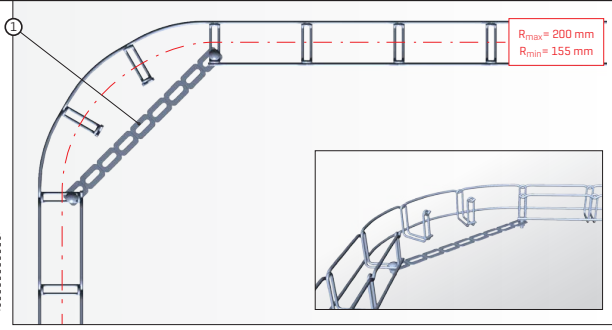
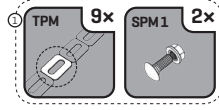
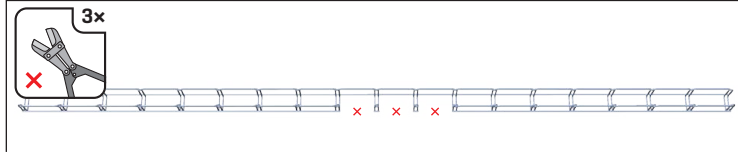
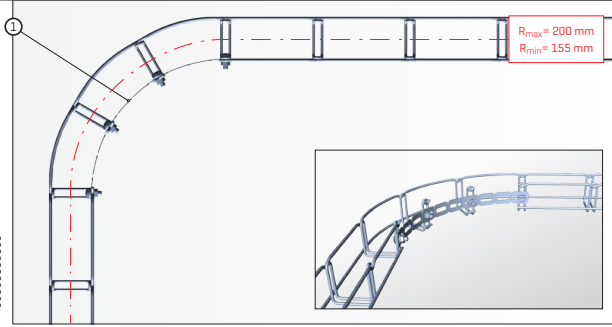
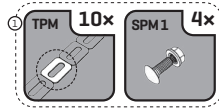
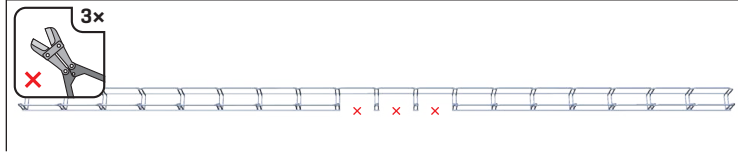

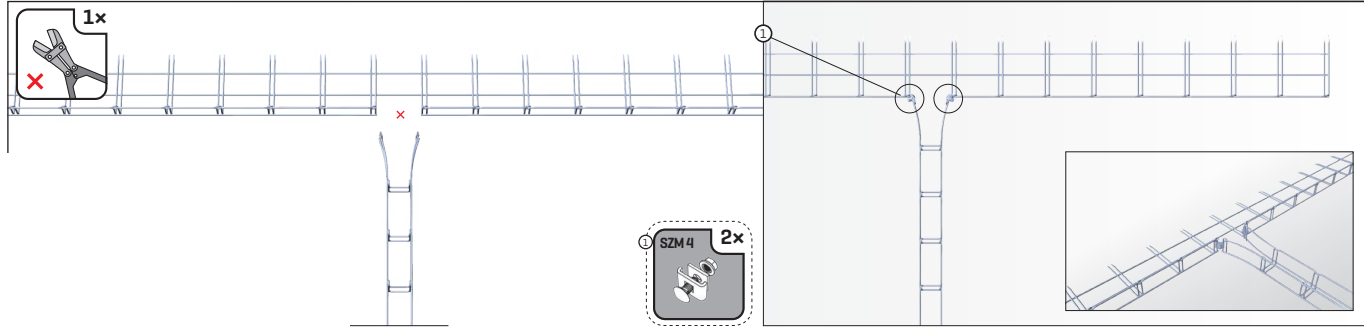

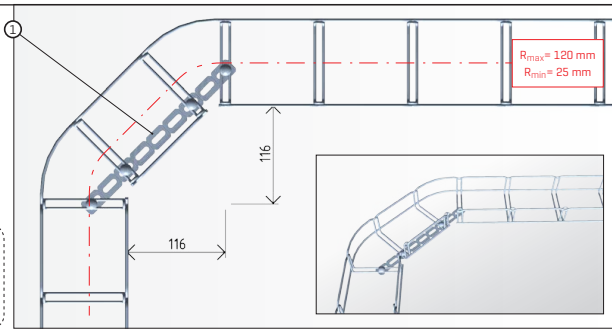
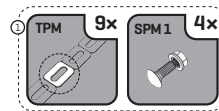
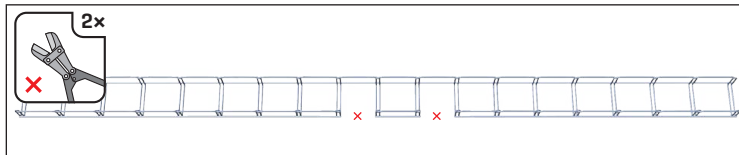
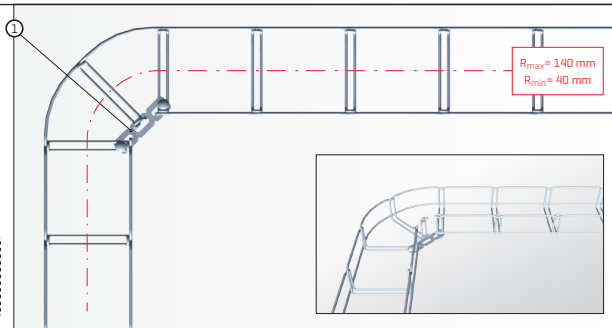
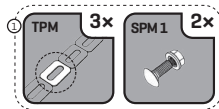
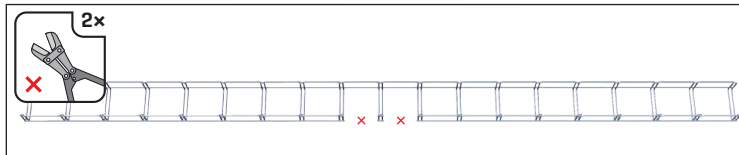

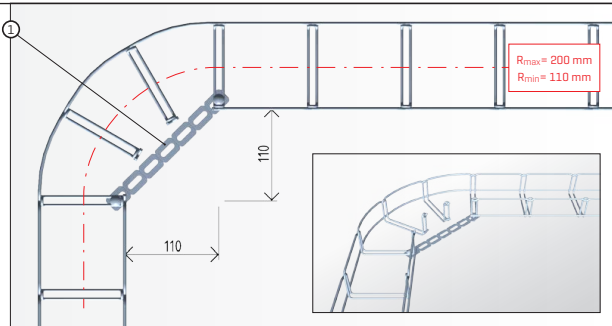
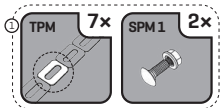
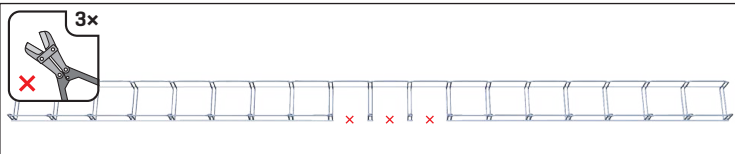
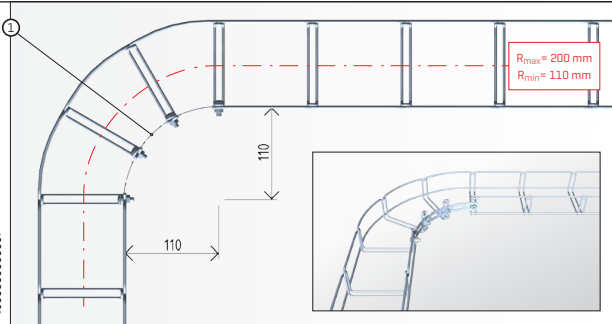
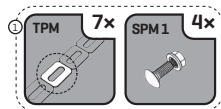
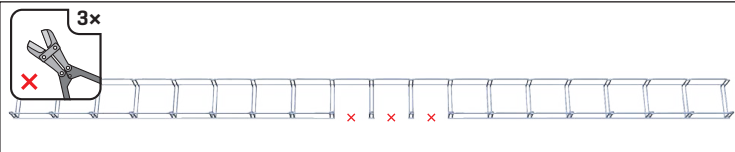

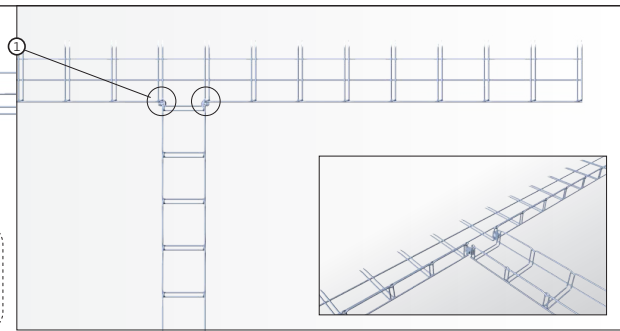
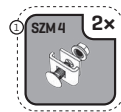
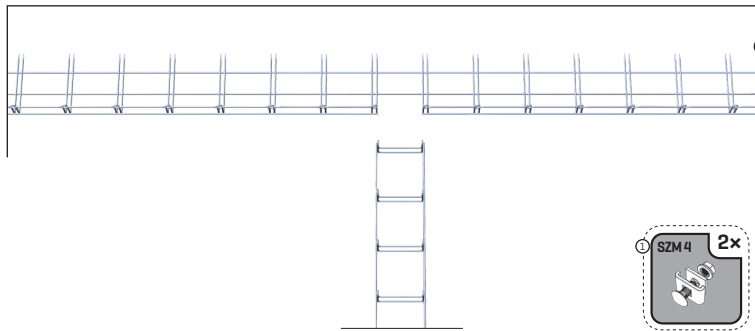
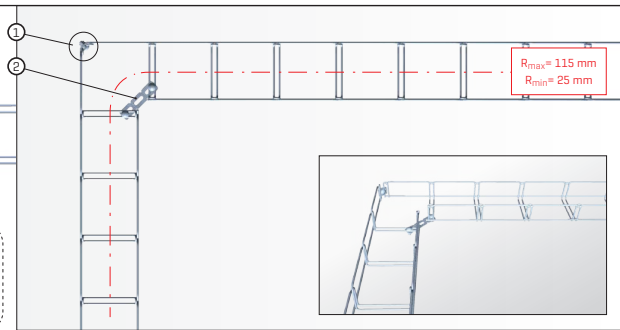
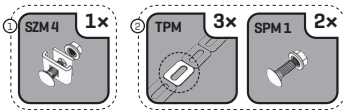
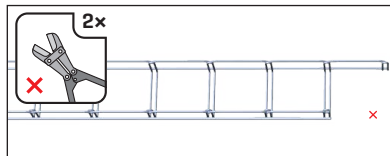

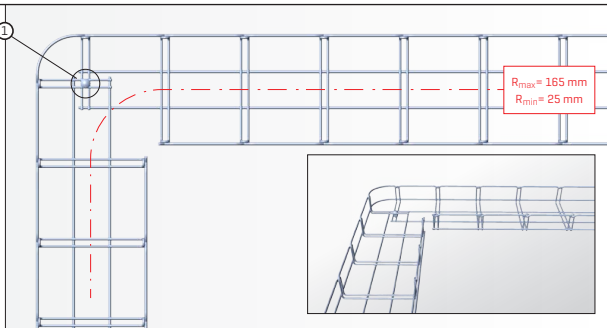
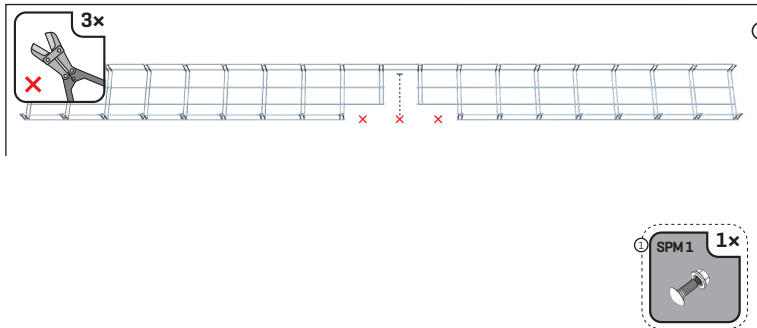
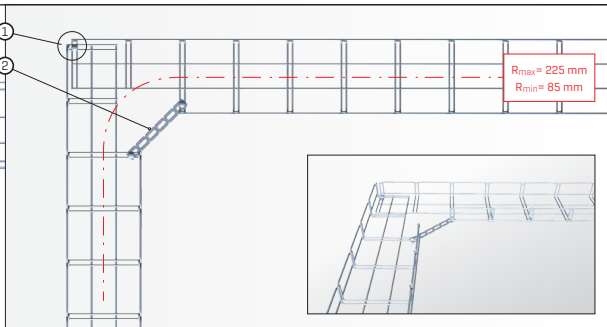
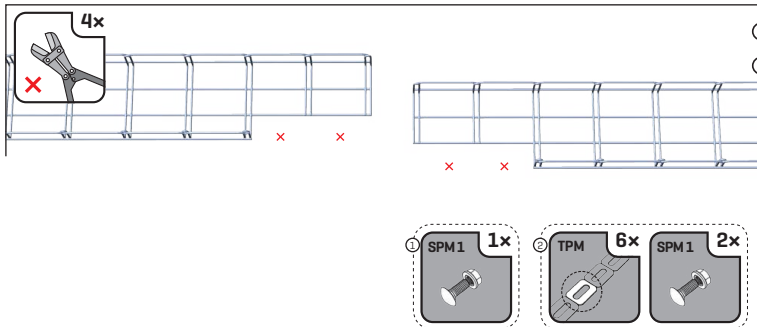

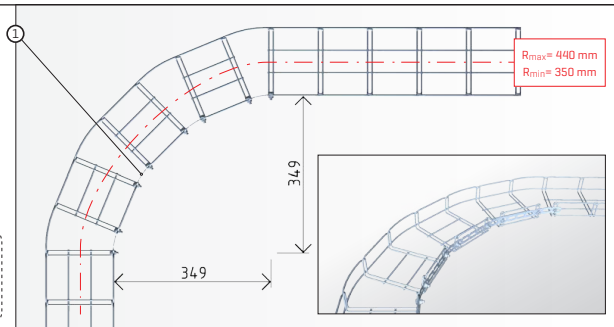
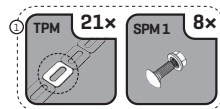
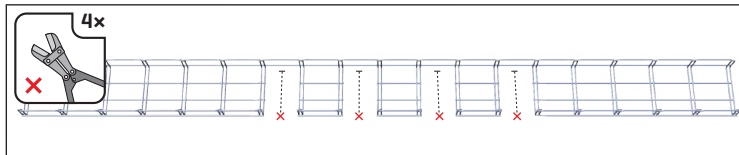
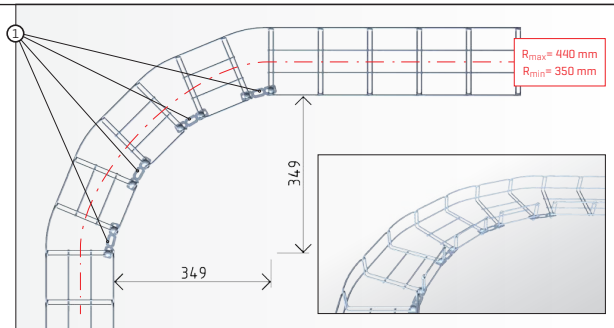
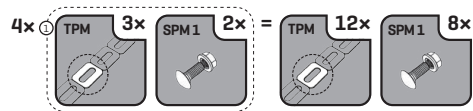
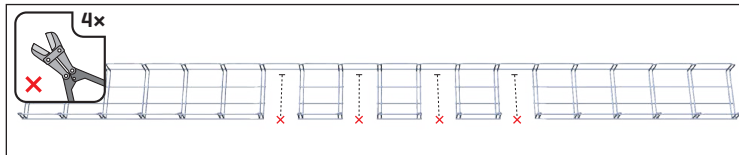

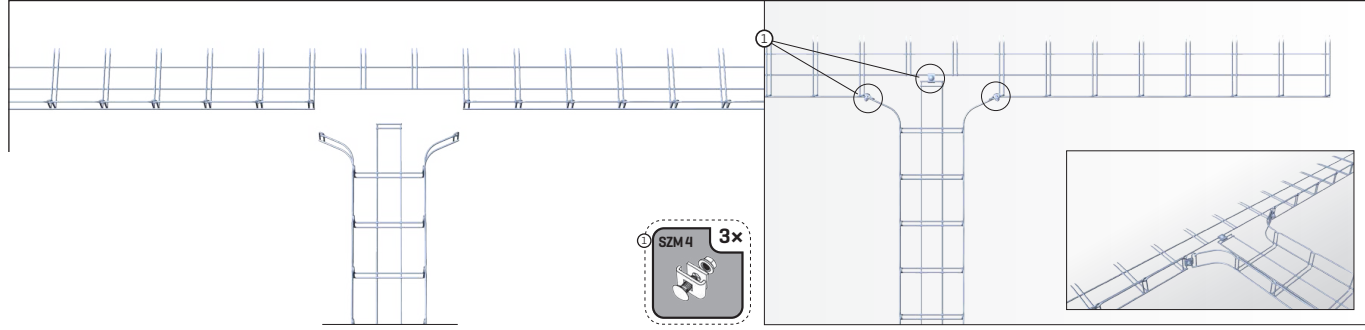



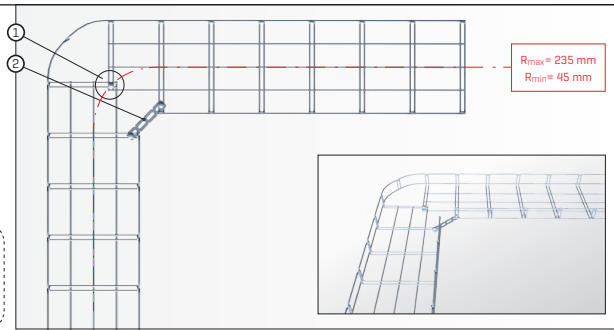
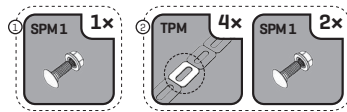
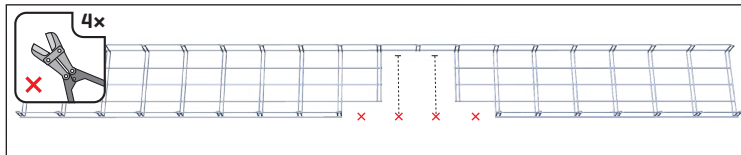
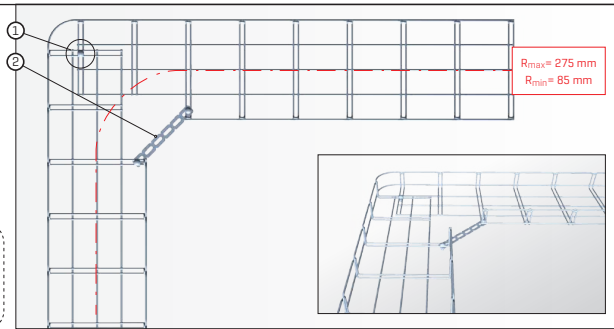
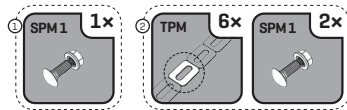
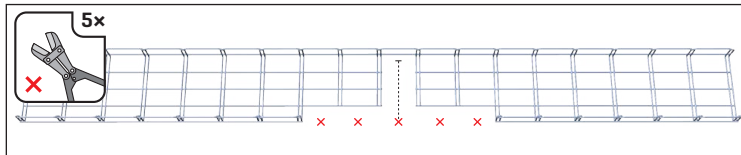

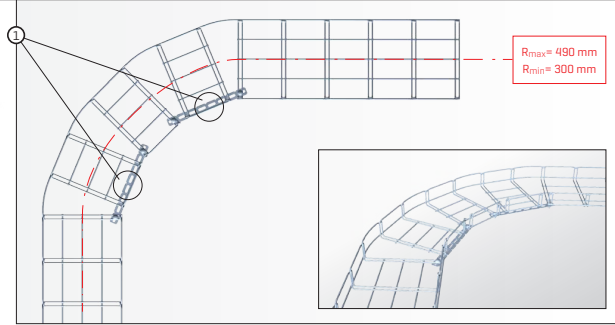
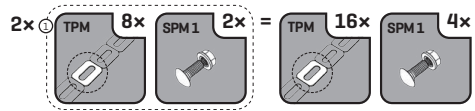
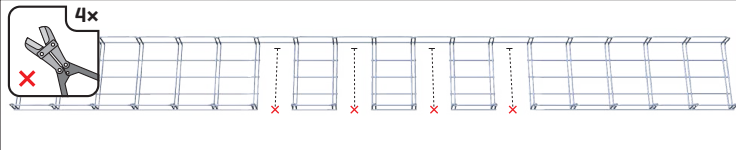

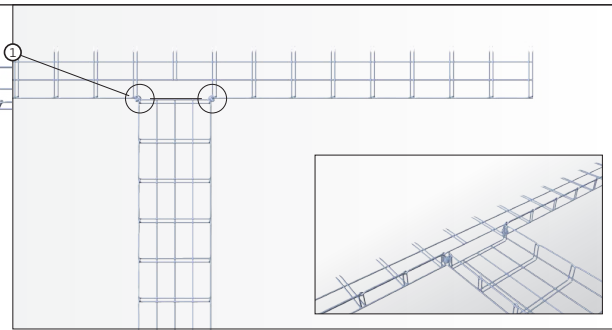
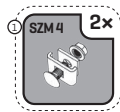
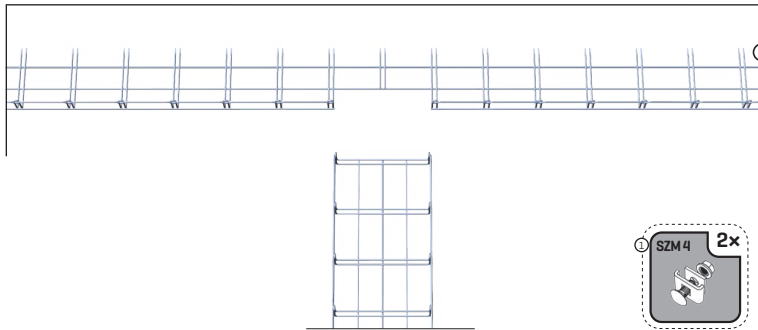
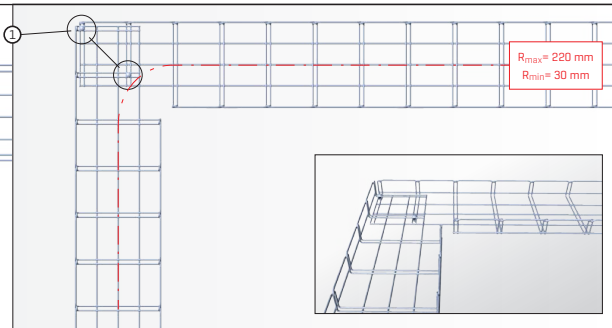
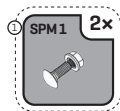
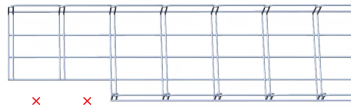
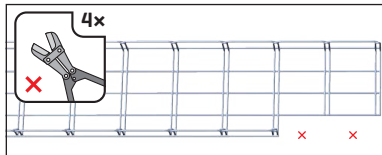

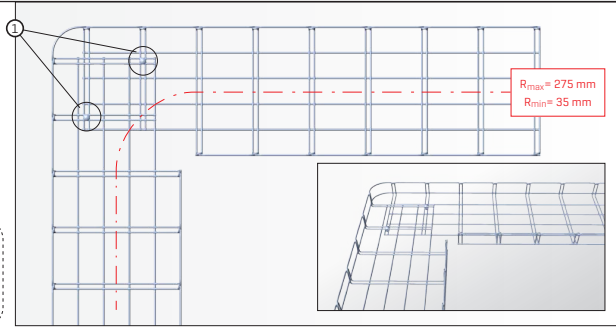
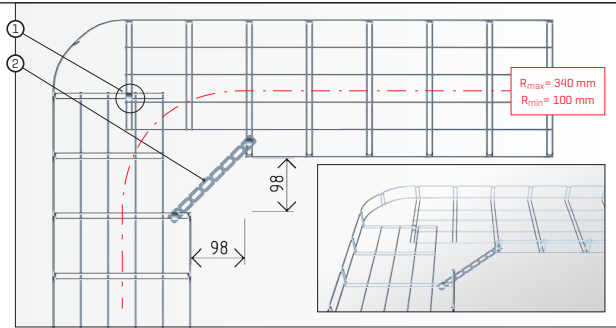
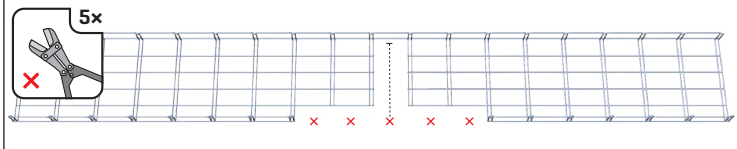
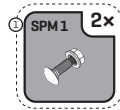
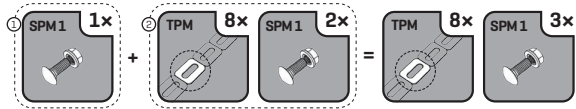
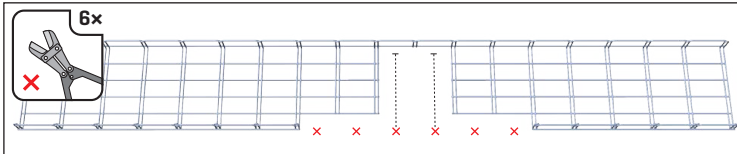

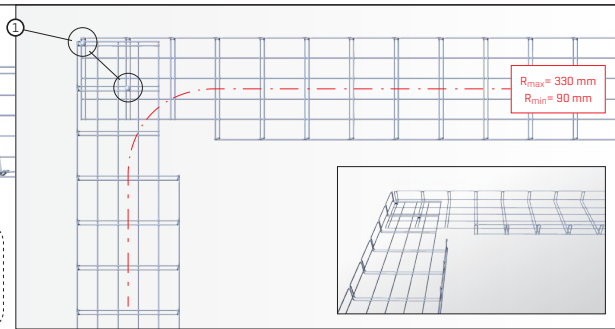
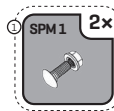
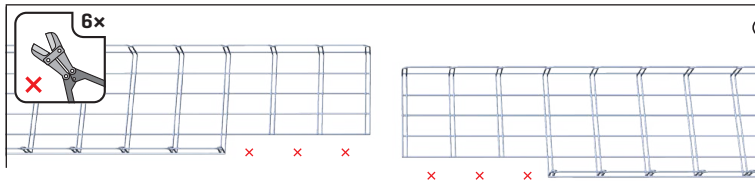
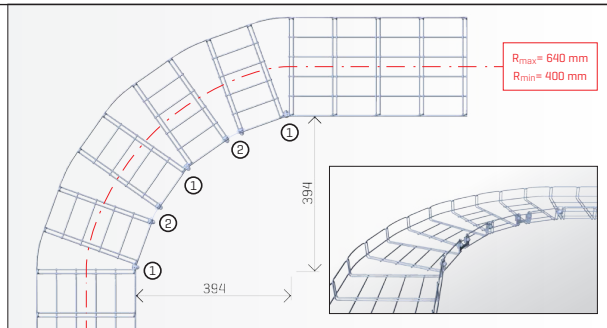
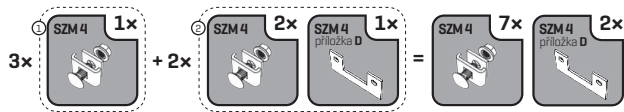
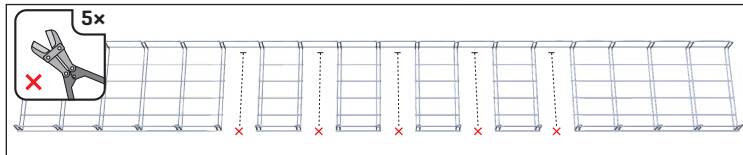

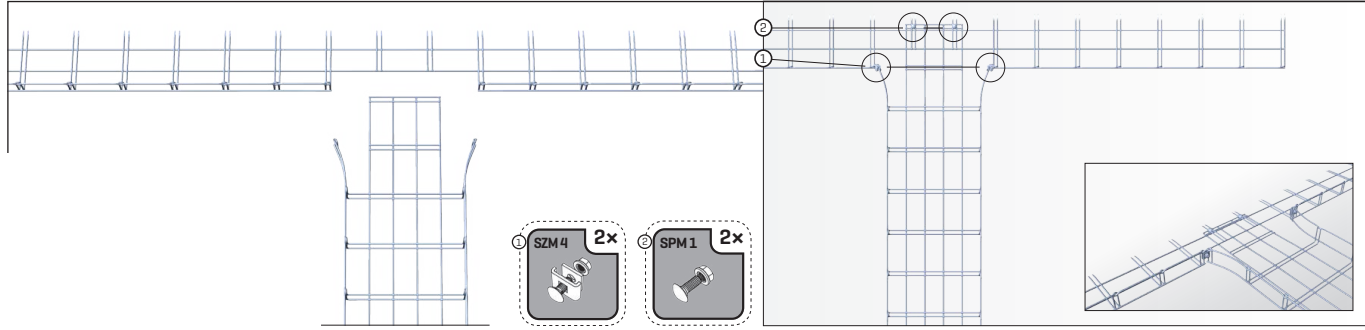

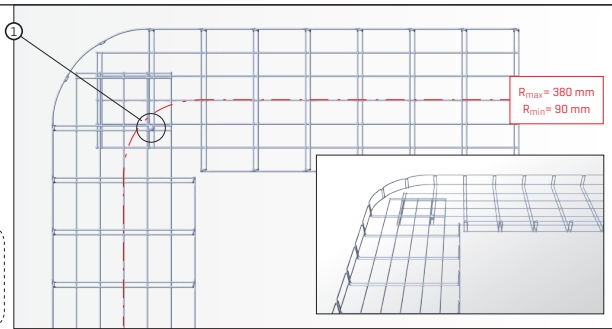
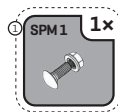
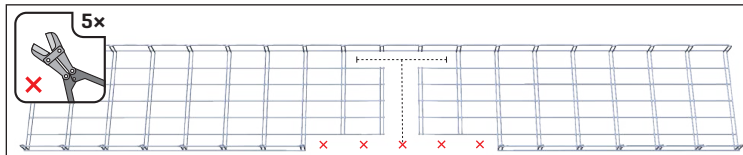
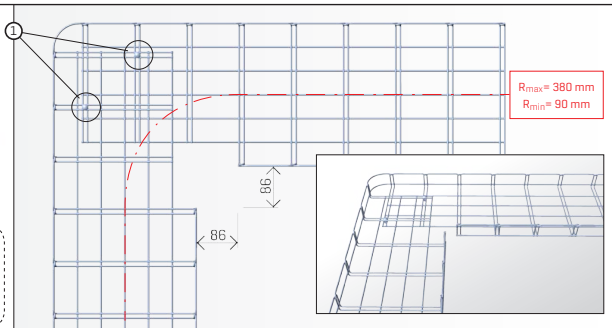
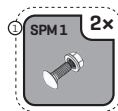
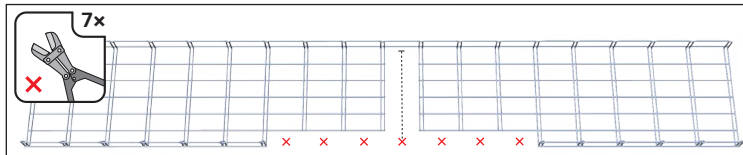

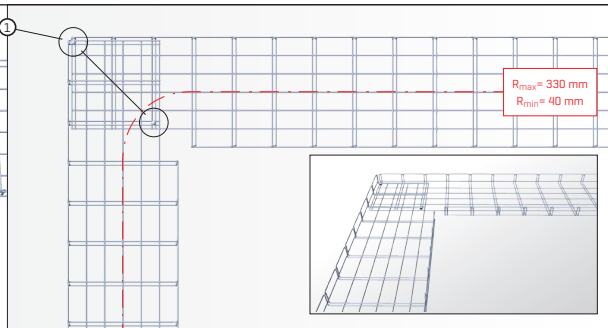
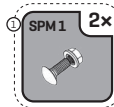
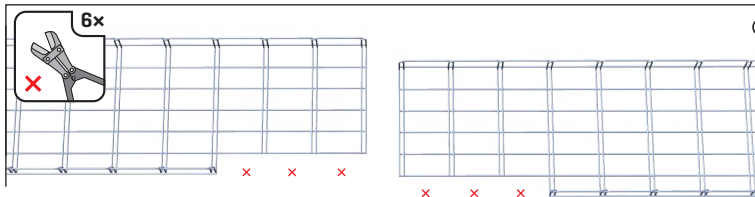
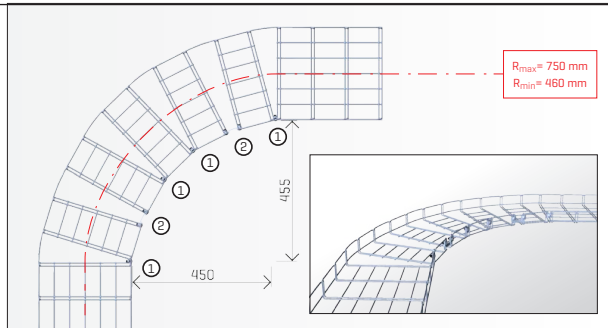
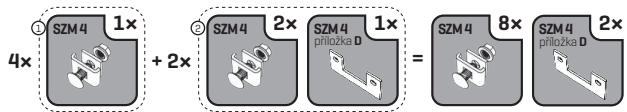
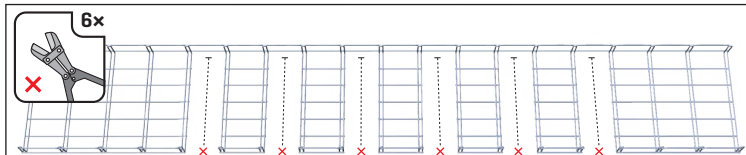



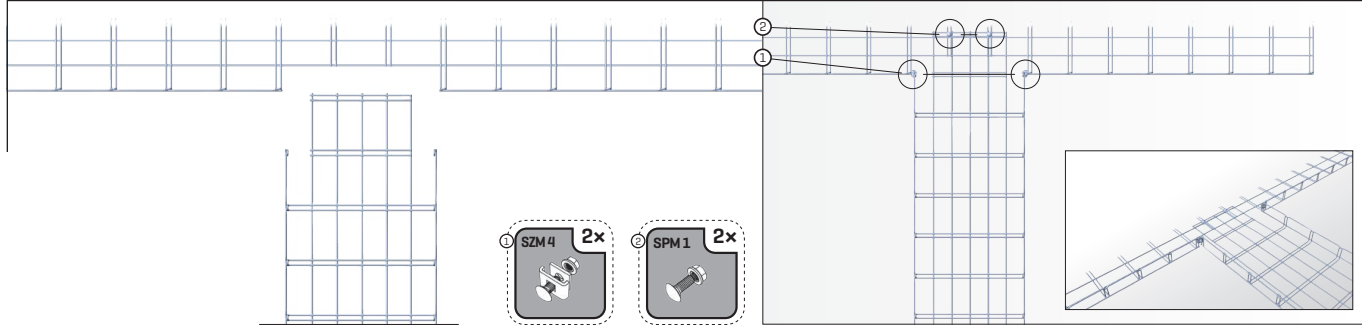

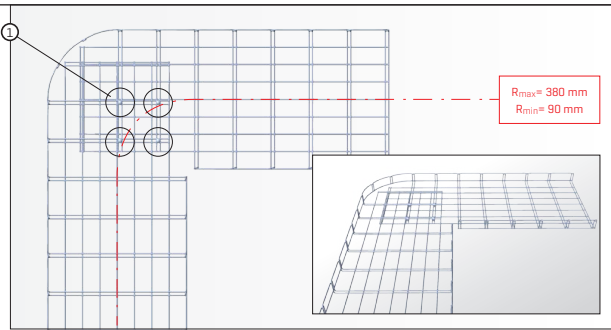
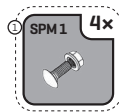
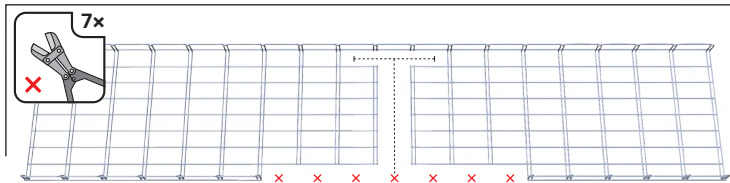

$R_{max} = 380 \text{ mm}$   
 $R_{min} = 90 \text{ mm}$

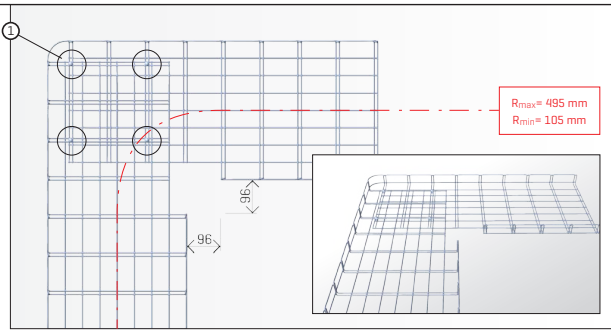
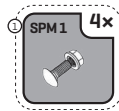
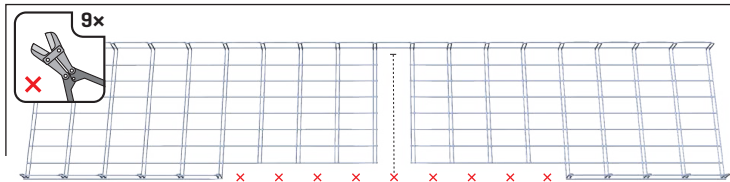

$R_{max} = 495 \text{ mm}$   
 $R_{min} = 105 \text{ mm}$

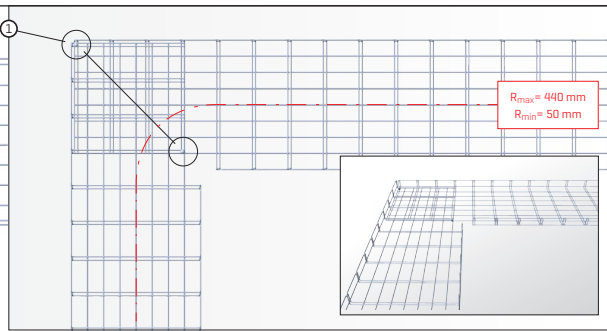
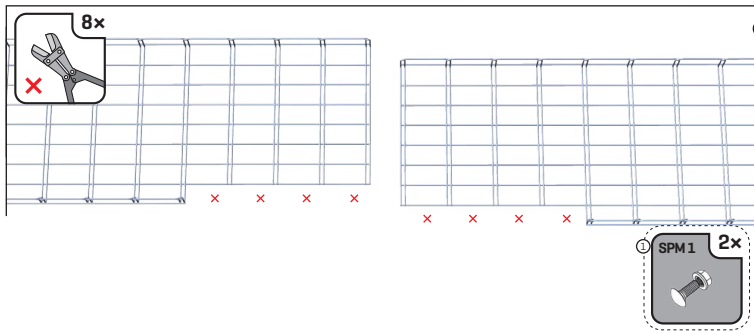
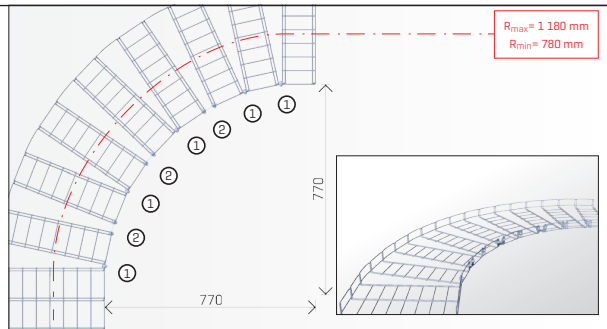
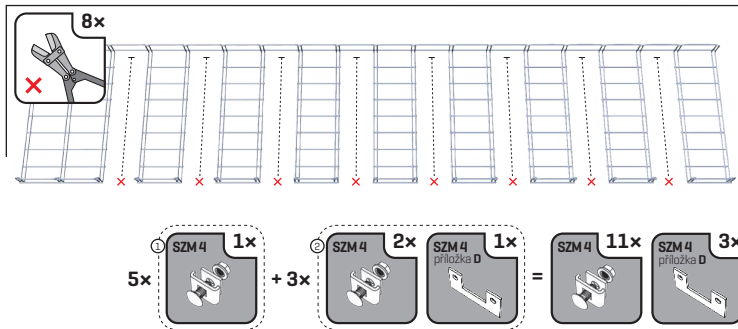

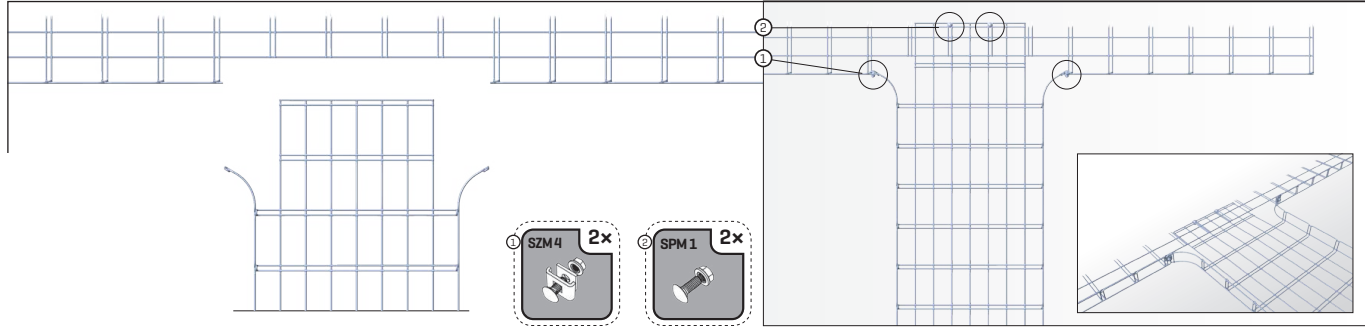

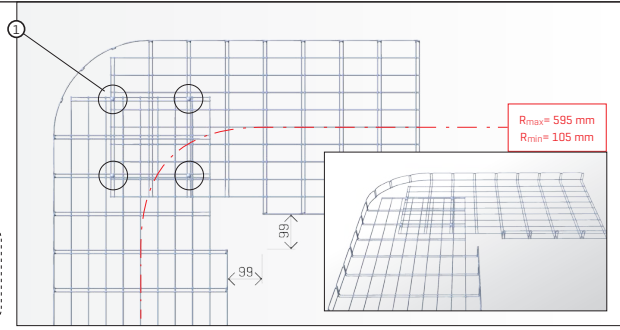
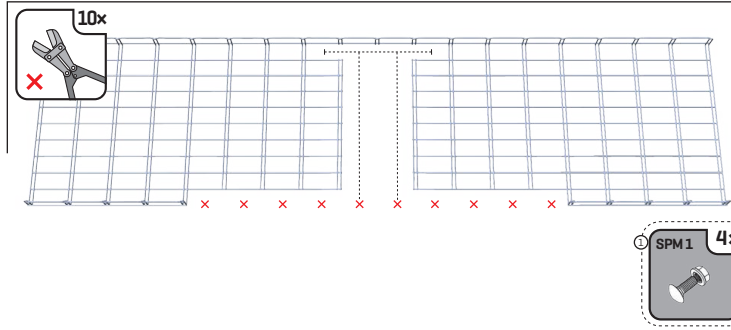
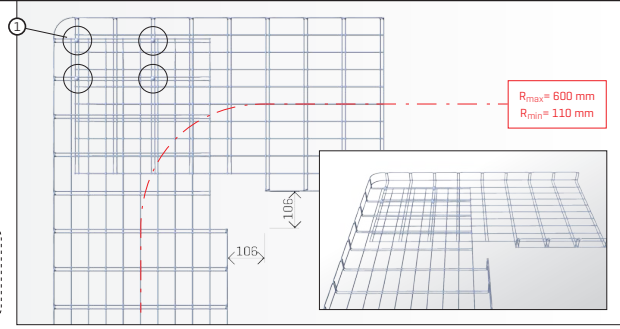
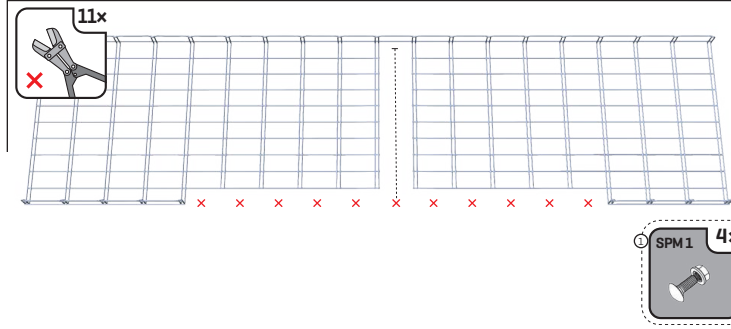

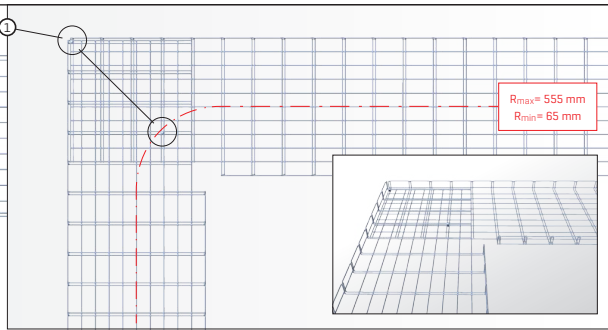
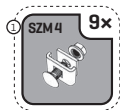
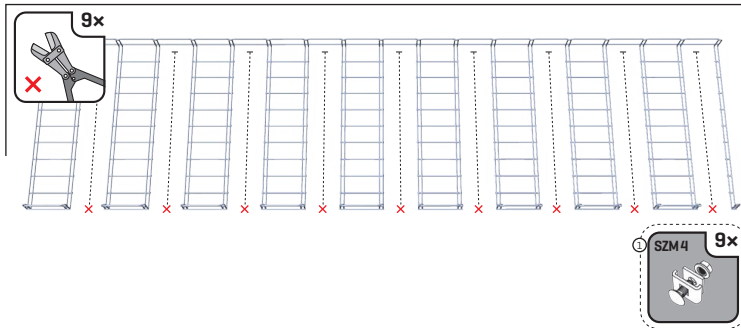
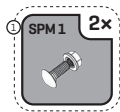
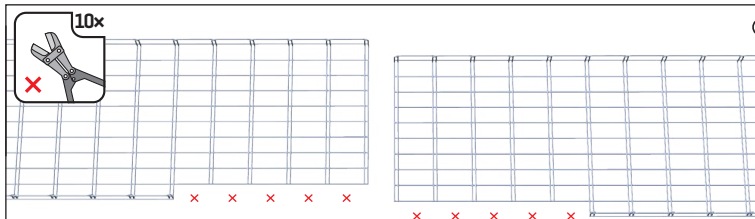

$R_{max} = 555 \text{ mm}$   
 $R_{min} = 65 \text{ mm}$

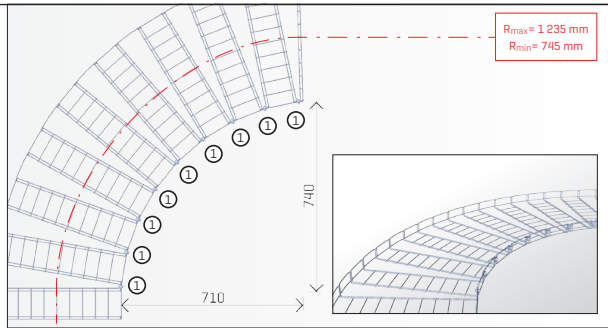

$R_{max} = 1\,235 \text{ mm}$   
 $R_{min} = 745 \text{ mm}$

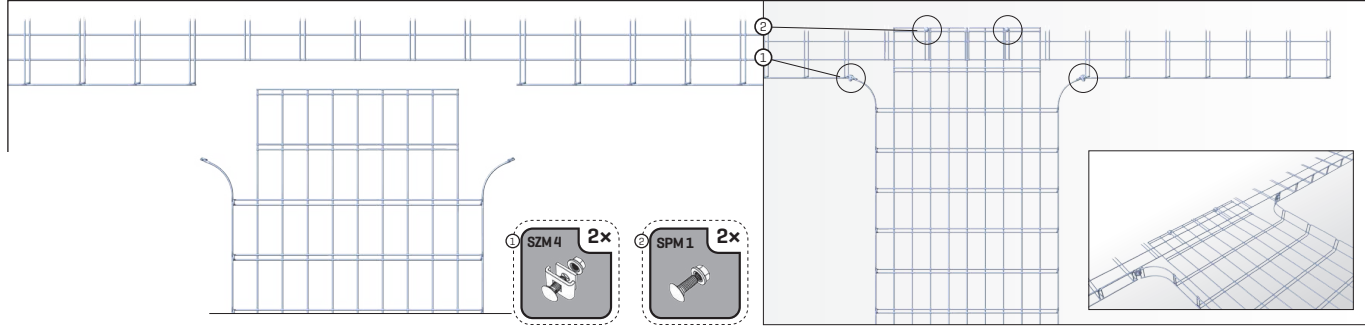

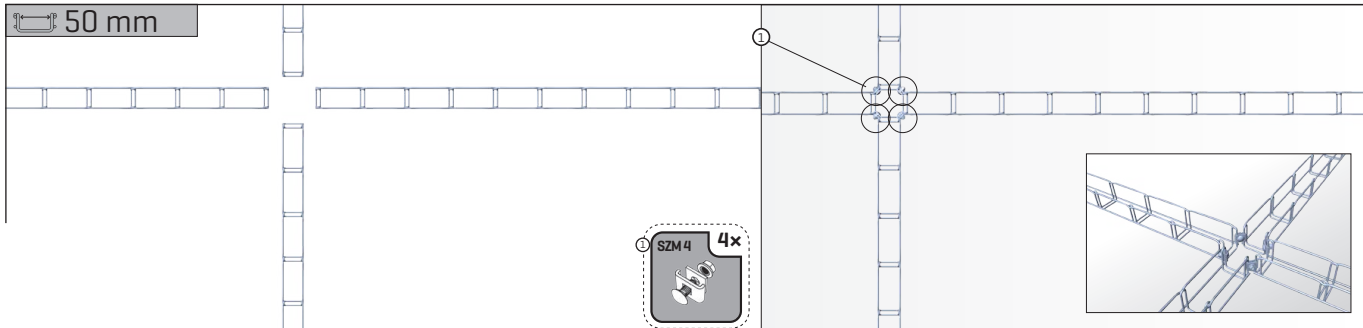
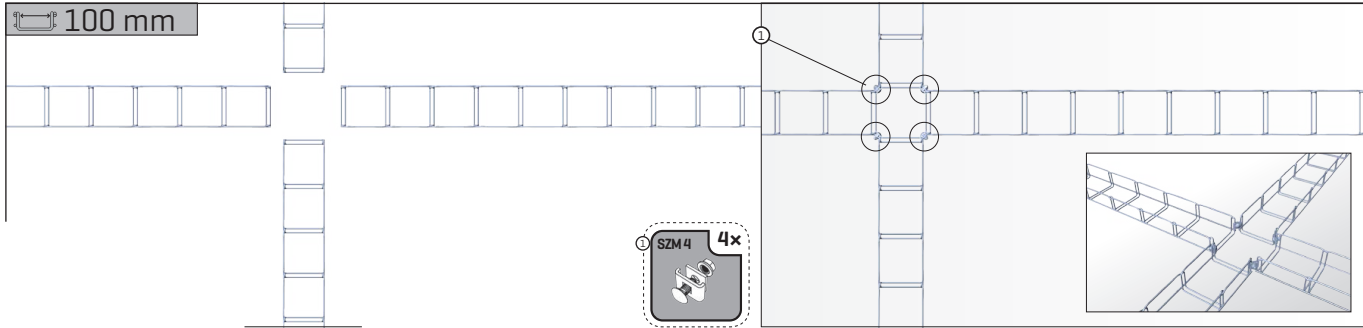

 50 mm 100 mm

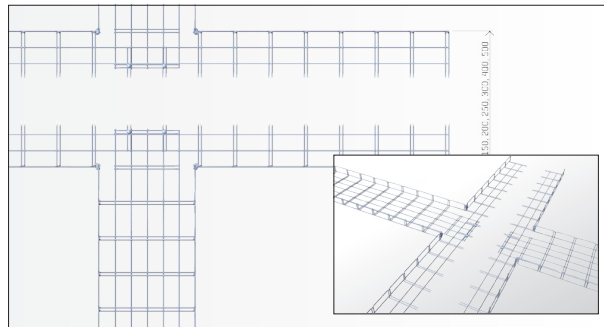
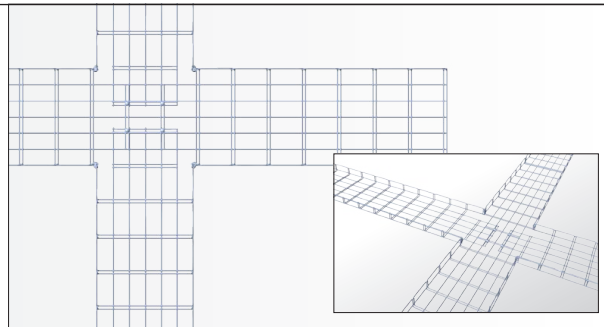
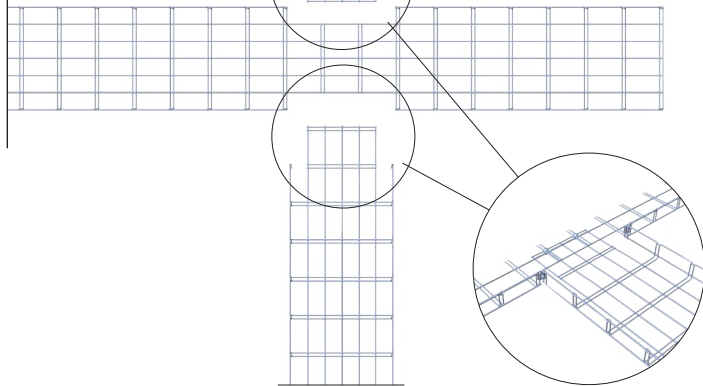

 150 - 300 mm

Křížení tras širších než 100 mm se provádí jako dva protilehlé T-spoje. Provedení spojů se řídí rozměrem připojované trasy. Šířka hlavní trasy v tomto případě nerozhoduje.

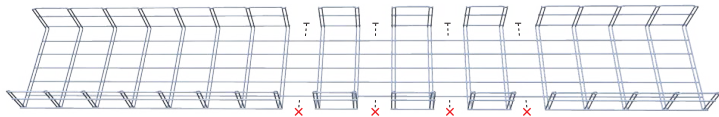

 50, 100 mm

4x

Prostorové ohyby tras jako přechod z vodorovné do svislé montáže se provádí podle požadavku na poloměr ohybu trasy. Při větším počtu prostřížení je možné dosáhnout ještě větších poloměru ohybu. Poloměry ohybů a ohýbací diagram platí i pro výšku bočnice 50 mm.

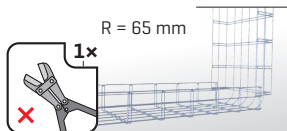

R = 65 mm

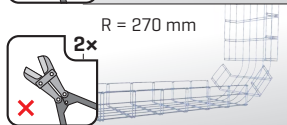

R = 270 mm

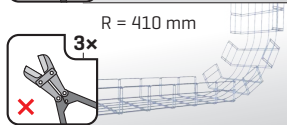

R = 410 mm

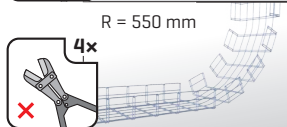

R = 550 mm

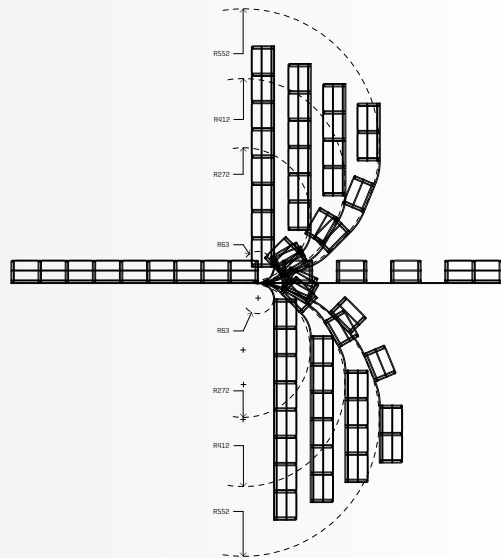

U 50 mm

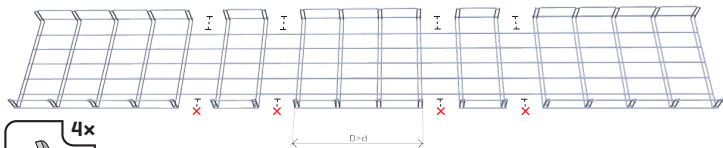

4x

Prostorové míjení se řídí rozměrem hlavní trasy a výškou bočnice ohýbané trasy.

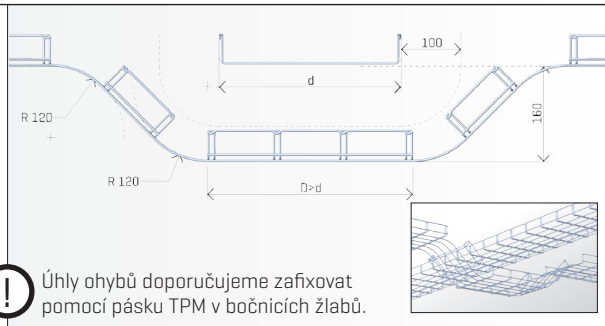

Úhly ohybů doporučujeme zafixovat pomocí pásky TPM v bočnicích žlabů.

U 100 mm

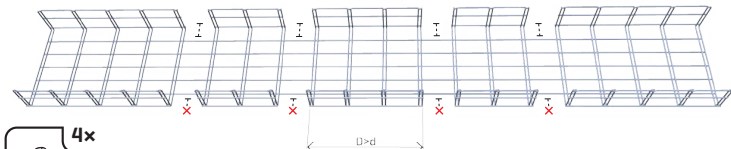

4x

Prostorové míjení se řídí rozměrem hlavní trasy a výškou bočnice ohýbané trasy.

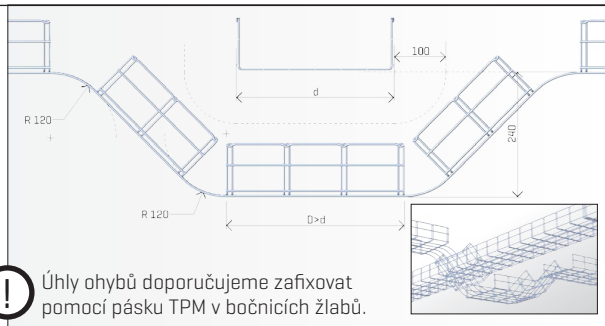

Úhly ohybů doporučujeme zafixovat pomocí pásky TPM v bočnicích žlabů.

### stranové napojení

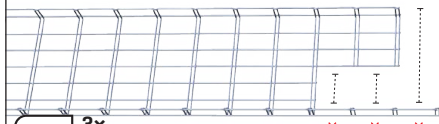

3x

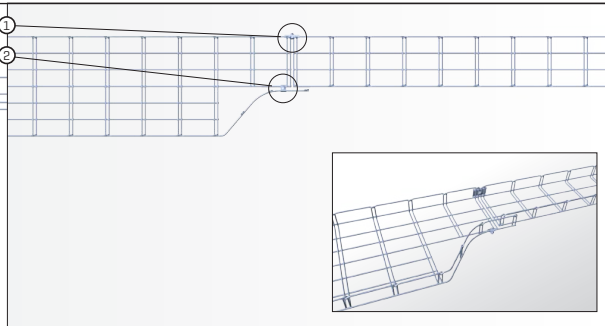
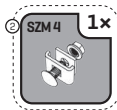
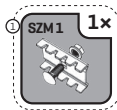

### středové napojení

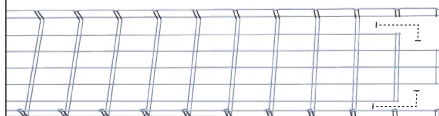

4x

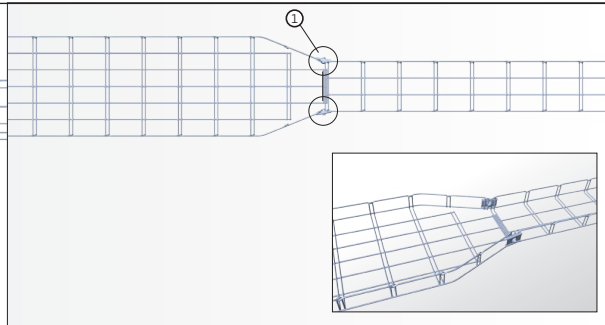
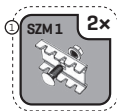

# kombinované napojení

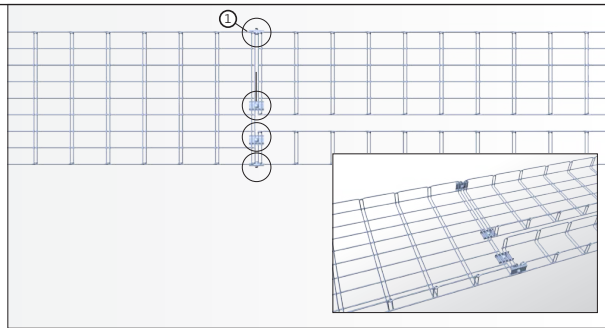
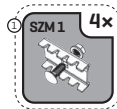
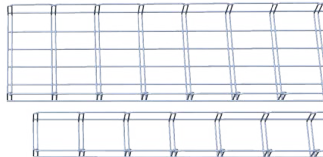
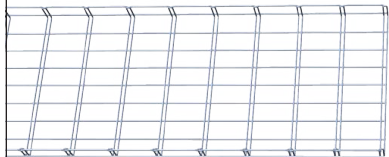

Informace a podrobnosti o jednotlivých prvcích systému a jeho možnostech pro montáže kabelových tras najdete v našich katalozích:

# MERKUR<sup>2</sup>

## GENERÁLNÍ KATALOG 2018-19

kompletní přehled prvků systému  
a jejich použití pro montáže  
kabelových tras systému

## POŽÁRNĚ ODOLNÉ TRASY

kompletní přehled odolných tras  
+ rozšířené možnosti kabelů  
= rozšířené možnosti klasifikací



Aktuální katalogy najdete  
na našich stránkách:

V tištěné podobě je žádejte  
u našich obchodníků.



# KONFIGURÁTOR KABELOVÝCH TRAS

Chytrý pomocník pro přípravu  
a realizaci kabelových tras

pomůže nadimenzovat trasu  
nabídne typy montáží tras  
vytvoří soupis materiálu  
odešle poptávku k nacenění  
instalovat už musíte sami :-]



aplikaci  
Konfigurátor  
kabelových tras  
najdete na:  
[www.merkur2.cz](http://www.merkur2.cz)



**ARKYS**<sup>®</sup>

[www.arkys.cz](http://www.arkys.cz)

ARKYS s.r.o.  
Tuřanka 115a, Brno 627 00  
Česká republika  
e-mail: [arkys@arkys.cz](mailto:arkys@arkys.cz)  
[www.arkys.cz](http://www.arkys.cz)

**ARKYS**<sup>®</sup>

06/2019 | Případné změny v dokumentu vyhrazeny společností Arkys, s.r.o.



[www.arkys.cz](http://www.arkys.cz)